

10G XFP 1550nm Single-Mode 80km Optical Transceiver XFP-10G55-80-xx



Features

- Supports 9.95Gb/s to 11.3Gb/s Bit Rates
- Hot-pluggable XFP Footprint
- Maximum Link Length up to 80km
- Temperature-Stabilized EML transmitter
- Duplex LC Connector
- Built-in Digital Diagnostic Functions
- Case Operating Temperature:
Standard: 0°C to 70°C
- No external clock required

Applications

- OC192/ STM 64
- 10GBASE-ZR/ZW 10G Ethernet
- 1200-SM-LL-L 10G Fiber Channel
- P1L1-2D2
- ITU-T G.709

Description

The XFP-10G55-80-xx series single mode transceiver is small form factor pluggable module for duplex optical data communications such as 10GBASE-ZR/ZW defined by IEEE 802.3ae. It is with the XFP 30-pin connector to allow hot plug capability. This module is designed for single mode fiber and operates at a nominal wavelength of 1550 nm.

The transmitter section uses a 1550nm EML, which is class 1 laser compliant according to International Safety Standard IEC-60825. The receiver section uses an integrated InGaAs detector preamplifier (IDP) mounted in an optical header and a limiting post-amplifier IC.

Specifications

Table 1 - Absolute Maximum Ratings **Note2*

Parameter	Symbol	Min	Typ	Max	Unit
Maximum Supply Voltage 1	V_{CC3}	-0.5		4.0	V
Maximum Supply Voltage 2	V_{CC5}	-0.5		6.0	V
Storage Temperature	T_S	-40		85	°C

Table 2 - Recommend operating condition

Parameter	Symbol	Min	Typ	Max	Unit
Case Operating Temperature	TOP	0		70	°C
Supply Voltage 1	V_{CC3}	3.13	3.3	3.45	V
Supply Voltage 2	V_{CC5}	4.75	5	5.25	V

Table 3 - Electrical Characteristics

Parameter	Symbol	Min	Typ	Max	Unit	Note
Main Supply Voltage	V_{CC5}	4.75		5.25	V	
Supply Voltage #2	V_{CC3}	3.13		3.45	V	
Supply Current – Vcc5 supply	Icc5			370	mA	
Supply Current – Vcc3 supply	Icc3			500	mA	
Module total power	P			3.5	W	
Transmitter						
Input Differential Impedance * <i>Note3</i>	Rin		100		Ω	1
Differential Data Input Swing	Vin,pp	120		820	mV	
Transmit Disable Voltage	V_D	2.0		V_{CC}	V	
Transmit Enable Voltage	V_{EN}	GND		GND+0.8	V	
Transmit Disable Assert Time				10	US	
Receiver						

Differential Data Output Swing * <i>Note3</i>	Vout,pp	340	650	850	mV	
Rise Time (20 – 80%)	tr			38	PS	2
Fall Time (20 – 80%)	tf			38	PS	2
LOS Fault * <i>Note4</i>	VLOS fault	Vcc – 0.5		VccHOST	V	3
LOS Normal * <i>Note4</i>	VLOS norm	GND		GND+0.5	V	3
Power Supply Rejection	PSR	See Note 4 below				4

Note3: After internal AC coupling

Note4.:Loss of signal is open collector. Logic 0 indicates normal operation; logic 1 indicates no signal detected

Table 4 - Optical Characteristics

Parameter	Symbol	Min	Typ	Max	Unit	Ref.
Transmitter						
Output Opt. Pwr: 9/125 SMF	Pout	0		+4	dBm	
Optical Wavelength	λ_c	1530		1565	nm	
Spectral Width (-20dB)	$\Delta \lambda$			1	nm	
Optical Extinction Ratio@10.3Gb/s	ER	9			dB	
Average Launch power of OFF transmitter	P_{OFF}			-30	dBm	
TX Jitter Generation (Peak-to-Peak)	Txj			0.1	UI	
TX Jitter Generation (RMS)	TXjRMS			0.01	UI	
Relative Intensity Noise	RIN			-130	dB/Hz	
Eye Mask		Compliant with ITU-T G.691				
Receiver						
Receiver Sensitivity @ 9.95Gb/s * <i>Note5</i>	Pmin			-24	dBm	
Receiver Sensitivity @ 10.3Gb/s * <i>Note5</i>	Pmin			-24	dBm	
Overload Power	Pmax	-7			dBm	

Optical Center Wavelength	λ_C	1270	1550	1600	nm	
Receiver Reflectance	Rrx			-27	dB	
LOS De-Assert	LOSD			-26	dBm	
LOS Assert	LOSA	-38			dBm	
LOS Hysteresis		0.5			dB	

Note5: Back to back, measured with a PRBS $2^{31}-1$ test pattern and ER=9dB, BER 1×10^{-12}

Table 5 - Pin Descriptions

PIN	Symbol	Name/ Description
1	GND	Module Ground
2	VEE5	Optional -5.2 Power Supply – Not required
3	Mod-Desel	Module De-select; When held low allows the module to , respond to 2-wire serial interface commands
4	Interrupt	Interrupt (bar); Indicates presence of an important condition which can be read over the serial 2-wire interface
5	TX_DIS	Transmitter Disable; Transmitter laser source turned off
6	VCC5	+5 Power Supply-Not Required
7	GND	Module Ground
8	VCC3	+3.3V Power Supply
9	VCC3	+3.3V Power Supply
10	SCL	Serial 2-wire interface clock
11	SDA	Serial 2-wire interface data line
12	Mod_Abs	Module Absent; Indicates module is not present. Grounded in the module
13	Mod_NR	Module Not Ready
14	RX_LOS	Receiver Loss of Signal indicator
15	GND	Module Ground
16	GND	Module Ground
17	RD-	Receiver inverted data output
18	RD+	Receiver non-inverted data output
19	GND	Module Ground
20	VCC2	+1.8V Power Supply – Not required
21	P_Down/RST	Power Down; When high, places the module in the low power stand-by mode and on the falling edge of P_Down initiates a module reset
		Reset; The falling edge initiates a complete reset of the module including the 2-wire serial interface, equivalent to

		a power cycle.
22	VCC2	+1.8V Power Supply – Not required
23	GND	Module Ground
24	RefCLK+	Reference Clock non-inverted input, AC coupled on the host board – Not required
25	RefCLK-	Reference Clock inverted input, AC coupled on the host board – Not required
26	GND	Module Ground
27	GND	Module Ground
28	TD-	Transmitter inverted data input
29	TD+	Transmitter non-inverted data input
30	GND	Module Ground

Host Board Connector Pin out

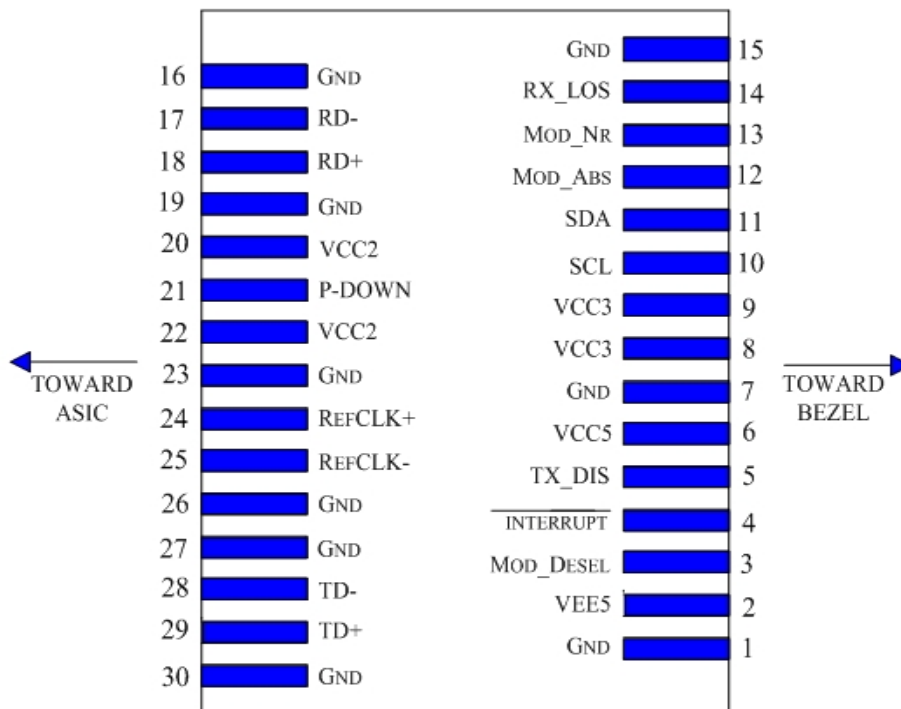

Digital Diagnostic Functions

FiberStore 's Small Form Factor 10Gb/s (XFP) transceivers are compliant with the current XFP Multi-Source Agreement (MSA) Specification Rev 4.5. As defined by the XFP MSA, FiberStore XFP transceivers provide digital diagnostic functions via a 2-wire serial interface, which allows real-time access to the following operating parameters:

- ◇ Transceiver temperature
- ◇ Laser bias current
- ◇ Transmitted optical power
- ◇ Received optical power
- ◇ Transceiver supply voltage

It also provides a sophisticated system of alarm and warning flags, which may be used to alert end-users when particular operating parameters are outside of a factory-set normal range. The operating and diagnostics information is monitored and reported by a Digital Diagnostics Transceiver Controller inside the transceiver, which is accessed through the 2-wire serial interface. When the serial protocol is activated, the serial clock signal (SCL pin) is generated by the host. The positive edge clocks data into the XFP transceiver into those segments of its memory map that are not write-protected. The negative edge clocks data from the XFP transceiver. The serial data signal (SDA pin) is bi-directional for serial data transfer. The host uses SDA in conjunction with SCL to mark the start and end of serial protocol activation. The memories are organized as a series of 8-bit data words that can be addressed individually or sequentially. The 2-wire serial interface provides sequential or random access to the 8 bit parameters, addressed from 000h to the maximum address of the memory.

Recommended Host Board Power Supply Circuit

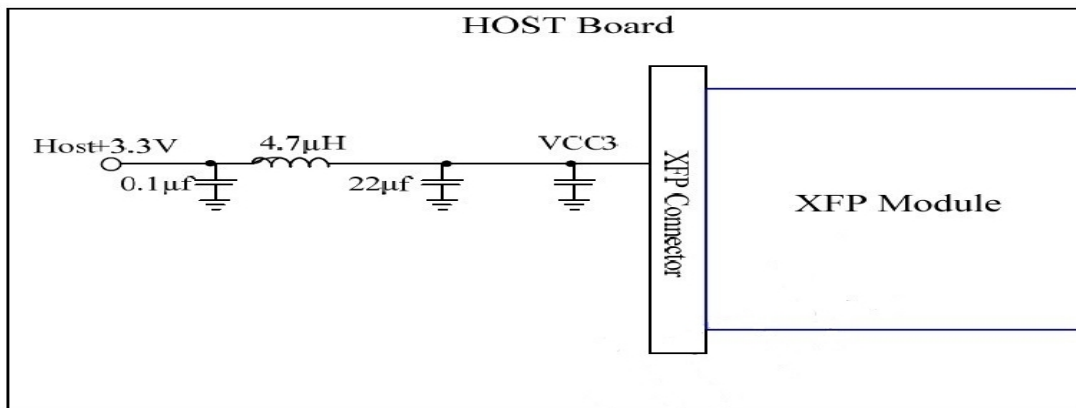

Recommended High-speed Interface Circuit

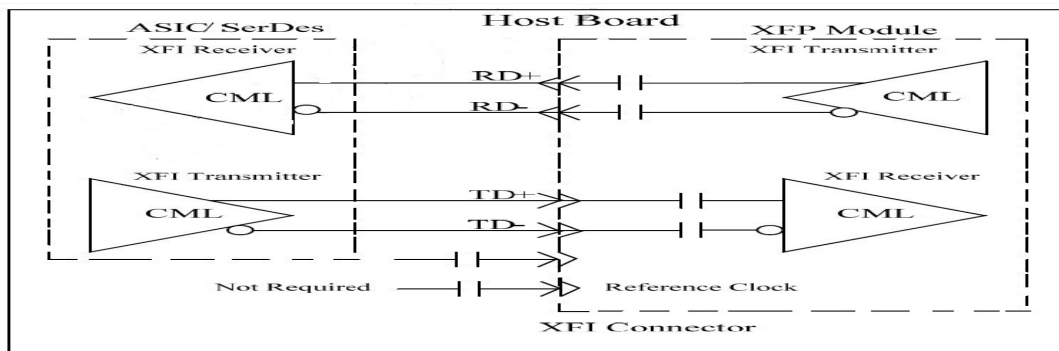

Mechanical Specifications

FiberStore's XFP transceivers are compliant with the dimensions defined by the XFP Multi-Sourcing Agreement (MSA).

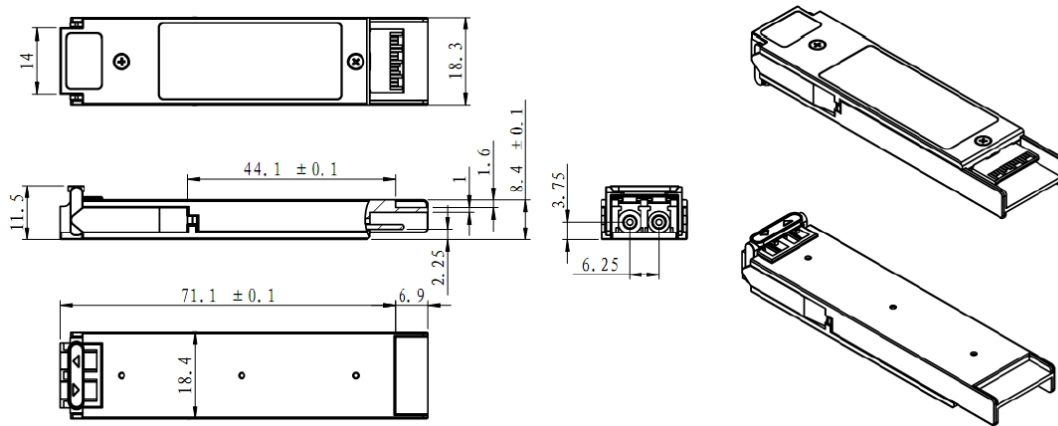

Ordering Information

Part No.	Data Rate (Gbps)	Wavelength (nm)	Connector Type	Transmission Distance (km)	Operating case temperature (°C)	Digital Diagnostics
XFP-10G55-80-xx	10	1550	LC	80	0 to +70	Yes

Notes:

xx means compatible brand. (For example: CO=Cisco, JU=Juniper, FD=Foundry, EX=Extreme, NE=Netgear,etc.)

FiberStore U.S.

X205 4181 129th Place SE, Bellevue
98006, WA,
United States
Tel: +1 (206) 453 0158
Fax: +1 (425) 505 2761

FiberStore Hong Kong

1220 Tung Chun Commercial Centre,
438-444 Shanghai Street, Kowloon,
HongKong
Tel: (852) 8120 3582
Fax: (852) 8120 3582

FiberStore China

5D Intelligent Tower,
Fumin Road Futian,
Shenzhen 518045, Guangdong,
China
Tel: +86 (755) 8300 3611
Fax: +86 (755) 8326 9395

Addresses, phone number and fax number also have been listed at www.fiberstore.com. Please e-mail us at sales@fiberstore.com or call us for assistance.

All statements, technical information, and recommendations related to the products herein are based upon information believed to be reliable or accurate. However, the accuracy or completeness thereof is not guaranteed, and no responsibility is assumed for any inaccuracies. Please contact FiberStore for more information.